

USED ON
31423
31424

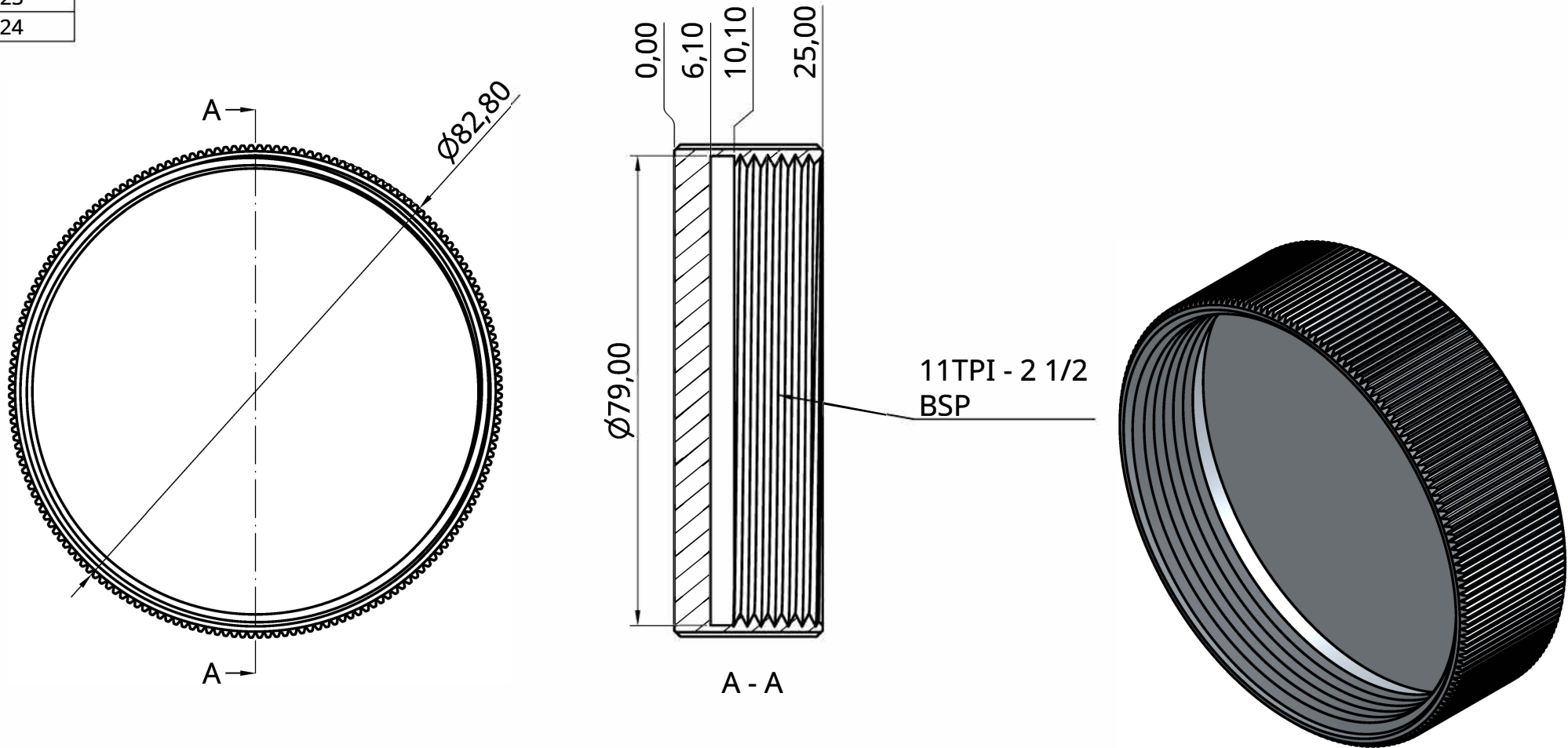

REMOVE ALL BURRS AND SHARP EDGES.(UNLESS OTHERWISE STATED). DO NOT SCALE.

THIS DOCUMENT IS DANIAMANT COPYRIGHT AND CONTAINS PROPRIETARY OWNED INTELLECTUAL PROPERTY RIGHTS AND CONFIDENTIAL DATA. ALL RIGHTS ARE STRICTLY RESERVED.THE INFORMATION MUST NOT BE USED EXCEPT FOR THE AGREED PURPOSE.UNAUTHORISED USE, REPRODUCTION, OR ISSUE TO ANY THIRD PARTY IS NOT PERMITTED WITHOUT THE PRIOR WRITTEN AUTHORITY OF DANIAMANT. THIS DOCUMENT IS TO BE RETURNED TO DANIAMANT WHEN THE AGREED PURPOSE IS FULFILLED.

THIS DOCUMENT IS UNCONTROLLED, UNLESS OTHERWISE STATED

MATERIAL : Steel

DIMENSIONS IN :- MM

TITLE.
Steel cap for skin fitting for 3D transducer



FINISH :-

3RD. ANGLE PROJECTION
B.S. 8888

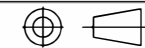

DRAWN
Franck

APPROVED
Daniamant

RELEASED
Daniamant

SCALE
1:1

TOLERANCES DS/ISO 2768 - m

DRAWING No.
31459

SHT. 1
OF
SHT. 1
A
4

0a			
ISSUE	CHG. No.	DATE	APPD